

Intermediate State Supply Chain Planning Co. Integration Architecture

This document is designed to show the "current thinking" integration architecture and to highlight different alternatives and or options for consideration

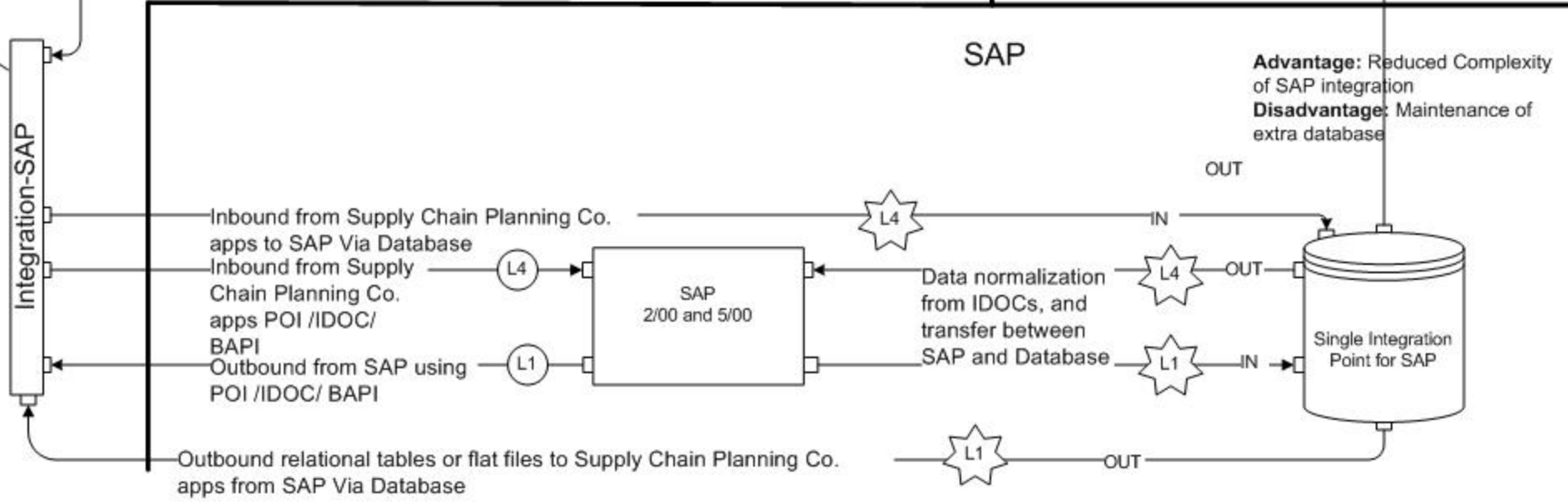
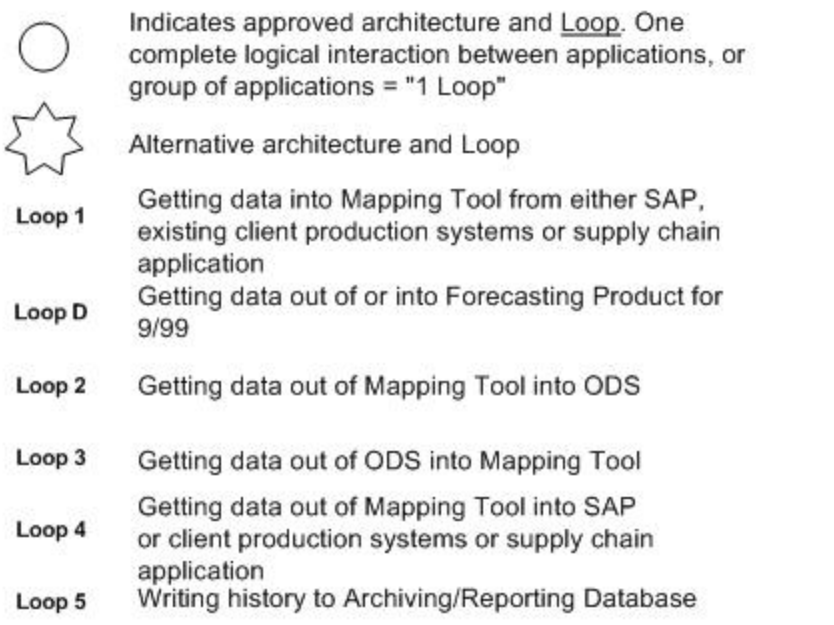
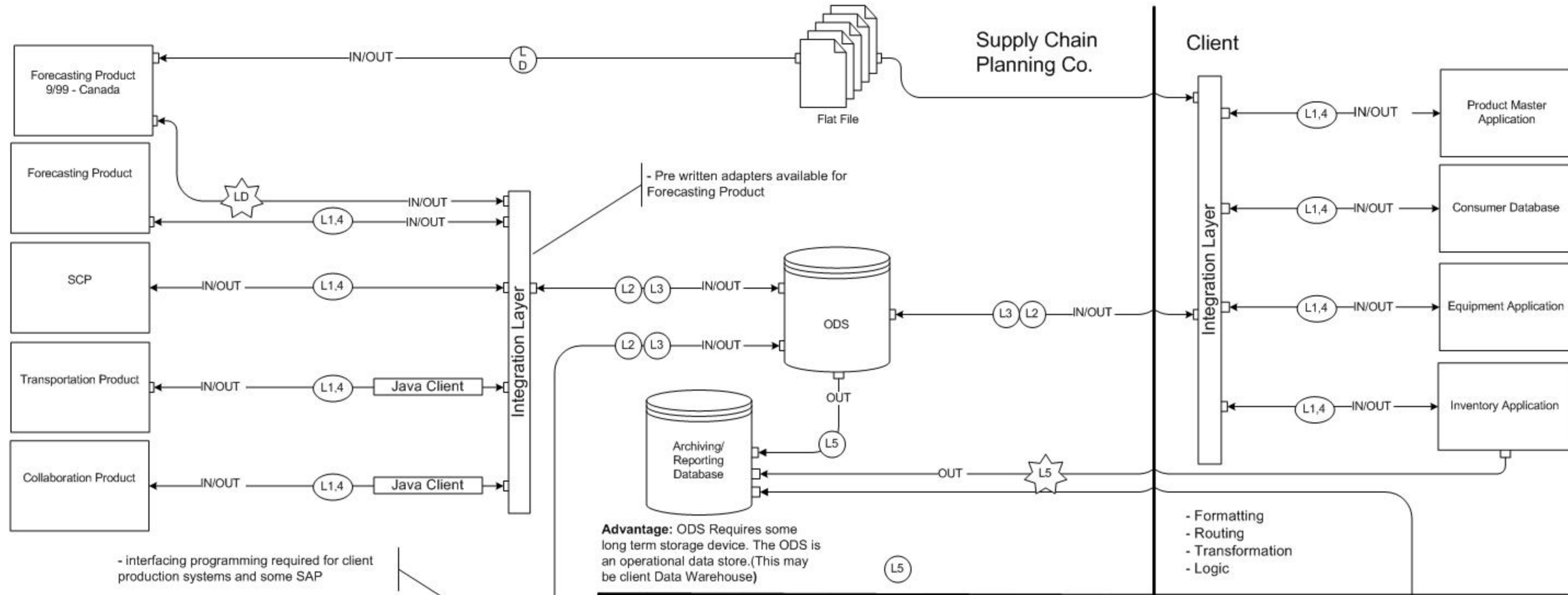

*Cycle time from SAP or Client production systems through Supply Chain Planning Co. must be < that 24

*Given that more data is extracted from SAP than imported into SAP, we may set up two integration tracts and use one for inbound and one for outbound